

AIR PREPARATION UNITS

AIR REGULATOR - series

Kushako

Air Regulator details :

Features :

- Suitable for panel & modular mountings.
- Adjusting knob with lock nut for locking at any set pressure.
- Diaphragm operated, relieving type.
- Pressure compensated by balanced poppet.
- Good flow & regulating characteristics.

Precautions :

- Note the direction of flow before installation & connect pipe accordingly.
- Nipples of taper threads to be used with teflon tape. Ensure teflon tape does not enter the unit during tightening. Nipples of straight threads to be used with sealing washer.
- Flush piping for dirt, dust, rust & other foreign particles.
- Install in clean atmosphere.

Technical Specifications:

Model	AR-2016-M
Medium	Compressed air - Filtered
Port Size	G1/2 BSP (F)
Pressure gauge port size	G1/4 BSP (F)
Flow rate (Ltr / Min)	4000
Maximum supply pressure (bar)	12
Regulating pressure range (bar)	0 - 2, 0 - 4, 0 - 7, 0 - 10 (Standard)
Ambient / Medium temperature	5° - 60° C
Installation	Any position
Materials of construction	Aluminium, Brass, Steel, SS, Nitrile
Optional accessories	Clamp, Modular mounting kit, Pr gauge
Weight (Kg)	0.820

- Supply pressure 7 bar, set pressure drop $p = 1$ bar (for Standard models) .

Pressure Setting :

- Loosen the lock nut provided on knob stud.
- Adjust the knob by turning into clockwise direction to increase the pressure.

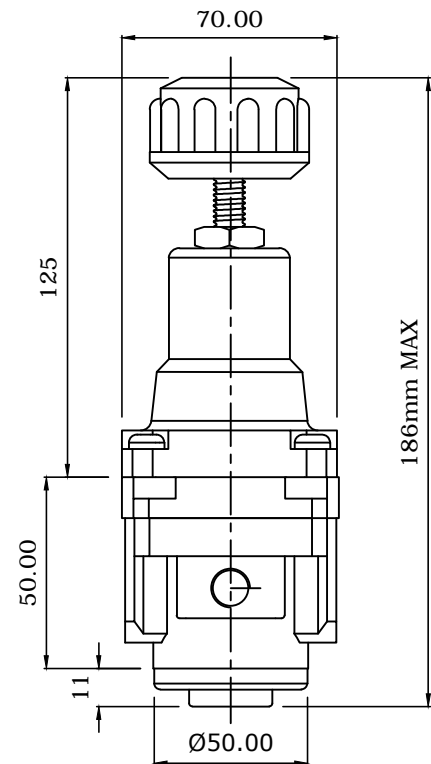

Manufactured by :

Kushako India

Office : 490, Narayan Peth, Opp. Pune Marathi Granthalaya, Pune - 411030. (Maharashtra), Website : www.kushakoindia.com

Works : Sr.No. 25/1A, Village Nanded, Sinhgad Road, Tal - Haveli, Dist. Pune -411041

Tel. No : 901169077 / 7620674777

E-mail : kushako.india@gmail.com / kushakoindia1992@gmail.com

Kushako